

# 上ぶた式U形側溝

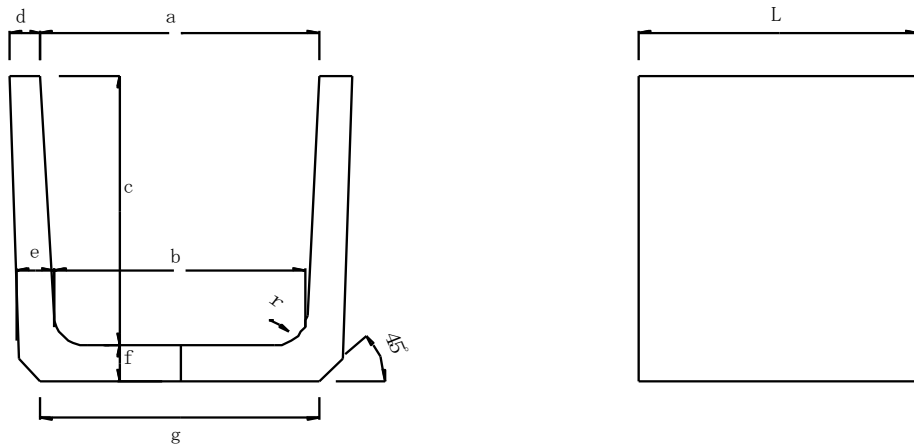

種類	呼び	寸法								
		a	b	c	d	e	f	g	r	L
U形側溝 1種	150	150	140	150	30	35	35	160	30	600
	180	180	170	180	35	40	40	190	50	
	240	240	220	240	45	50	50	240		
	300A	300	260	240	50	60	60	300		
	300B	300	260	300	50	60	60	300		
	300C	300	260	360	50	60	65	300		
	360A	360	310	300	50	65	65	360		
	360B	360	310	360	50	65	65	360		
	450	450	400	450	55	70	70	430	70	
	600	600	540	600	70	80	80	600		
U形側溝 2種	180	180	170	180	35	40	40	190	50	600
	240	240	220	240	45	50	50	240		
	300A	300	260	240	50	60	60	300		
	300B	300	260	300	50	60	60	300		
	300C	300	260	360	50	60	65	300		
	360A	360	310	300	50	65	65	360		
	360B	360	310	360	50	65	65	360		
	450	450	400	450	55	70	70	430	70	
	600	600	540	600	70	80	80	600		
寸法許容値		± 2	—	± 2	± 2	—	± 3	—	—	± 3

# 上ぶた式U形側溝用ふた

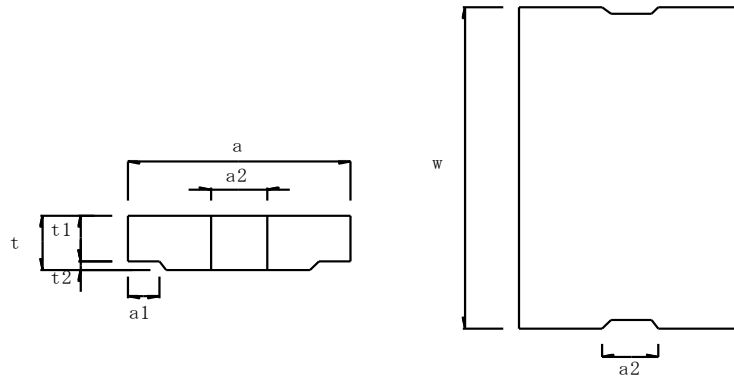

種類	規格	寸法							
		a	a1	a2	t	t1	t2	w	r
U形側溝用ふた 1種	150	210	35	75	35	30	5	600	15
	180	250	40	75	40	35	5		
	240	330	50	90	45	40	5		
	300	400	55	100	60	50	10		
	360	460	55	120	65	55	10		
	450	560	60	150	70	60	10		
	600	740	75	150	75	65			18
U形側溝用ふた 2種	180	250	40	75	90	80	10	600	15
	240	330	50	90	100	85	15		
	300	400	55	100	100	85	15		
	360	460	55	120	100	85	15		
	450	560	60	120	120	100	20		
	600	740	75	150	150	130	20		18
寸法許容値		± 3	± 2	—	± 2	± 2	—	± 3	—